

## 15 Implement drive system

<b>15.1</b>	<b>Power take-off</b> .....	<b>15-3</b>
15.1.1	Electronic components location for the power take-off system .....	15-3
<b>15.2</b>	<b>Power take-off system</b> .....	<b>15-5</b>
15.2.1	Remove the power take-off modulating valve .....	15-5
15.2.2	Install the power take-off modulating valve .....	15-5
15.2.3	Remove the power take-off drive shaft .....	15-6
15.2.4	Disassemble the power take-off drive shaft .....	15-13
15.2.5	Assemble the power take-off drive shaft .....	15-14
15.2.6	Install the power take-off drive shaft .....	15-16
15.2.7	Remove the power take-off clutch assembly .....	15-21
15.2.8	Install the power take-off clutch assembly .....	15-26
15.2.9	Remove the power take-off gearbox .....	15-30
15.2.10	Install the power take-off gearbox .....	15-32
<b>15.3</b>	<b>Power take-off system testing and adjusting</b> .....	<b>15-36</b>
15.3.1	Power take-off pressure test introduction .....	15-36
15.3.2	Do a test of the power take-off clutch pressure .....	15-36
15.3.3	Do a test of the pressure of the power take-off clutch lubricating oil .....	15-36



## 15.1 Power take-off

### 15.1.1 Electronic components location for the power take-off system

Electrical block diagram for the power take-off (PTO) system.

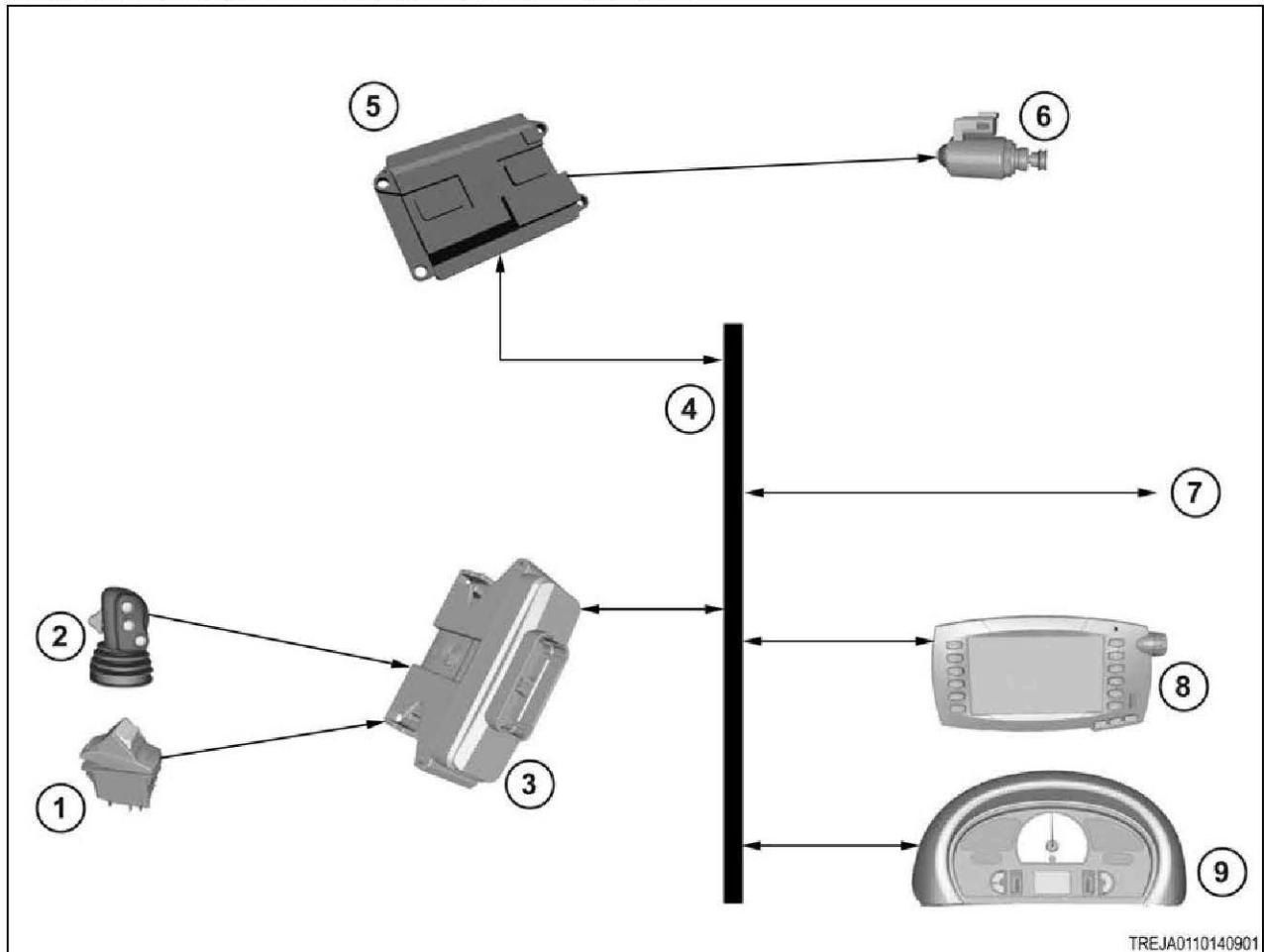

Fig. 1

- 1 PTO switch
- 2 One touch switch
- 3 Armrest module
- 4 CAN data link
- 5 Machine module
- 6 PTO solenoid
- 7 To the machine modules and the service connector
- 8 The virtual terminal
- 9 Dash panel cluster

The machine module controls the solenoid for the modulating valve.

The PTO can be engaged or disengaged with the PTO switch or the one touch switch.

The PTO can also be disengaged with the 3-point linkage.

The virtual terminal is used to view the rpm of the PTO.

The CAN data link is a serial communication bus that communicates with the following components:

- Engine module
- Machine module
- Virtual terminal
- Dash panel cluster

15. Implement drive system

- Autoguide receiver
- Other electronic modules

## 15.2 Power take-off system

### 15.2.1 Remove the power take-off modulating valve

**NOTE:** Clean all parts completely and let the parts air dry. Do not use wiping rags which will deposit lint. Check the parts and replace worn or damaged parts.

#### Procedure

1. Disconnect the harness assembly from the coil (1).

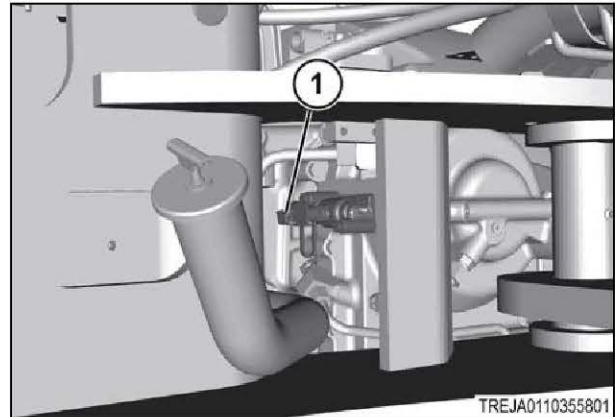

Fig. 2

2. Remove the bolts (1), the modulating valve (2), and the seal (3).

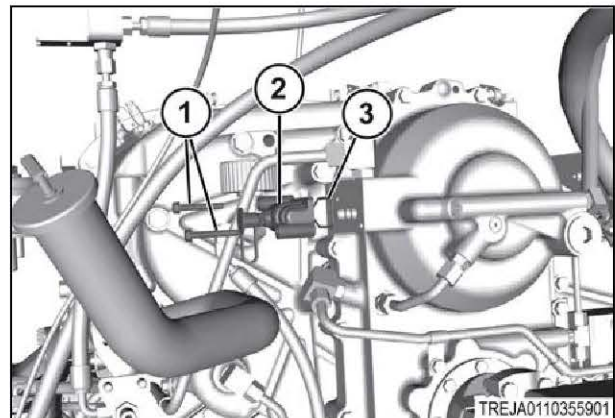

Fig. 3

### 15.2.2 Install the power take-off modulating valve

#### NOTE:

Clean all parts completely and let the parts air dry. Do not use wiping rags which will deposit lint. Check the parts and replace worn or damaged parts.

**Procedure**

1. Install the seal (3), the modulating valve (2), and the bolts (1).

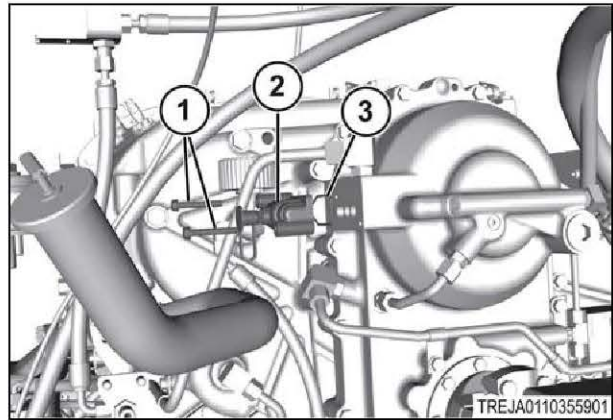

Fig. 4

2. Connect the harness assembly to the coil (1).

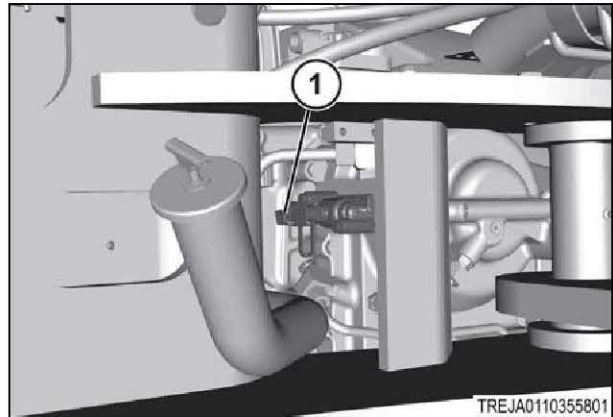

Fig. 5

**15.2.3 Remove the power take-off drive shaft****Procedure**

1. Park the machine on a solid, level surface. Stop the engine, apply the parking brake, and take the key with you.

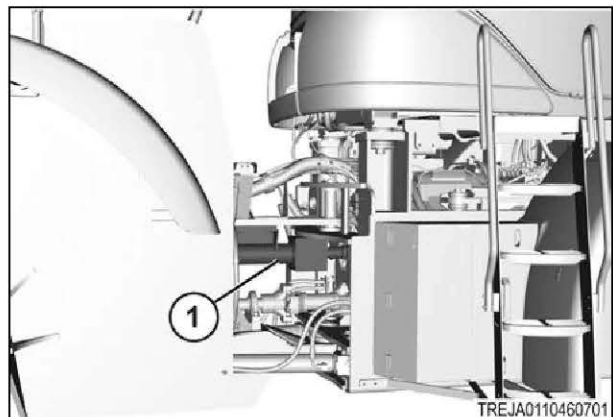

Fig. 6

2. Remove the four bolts (1) from cover for the front universal joint.

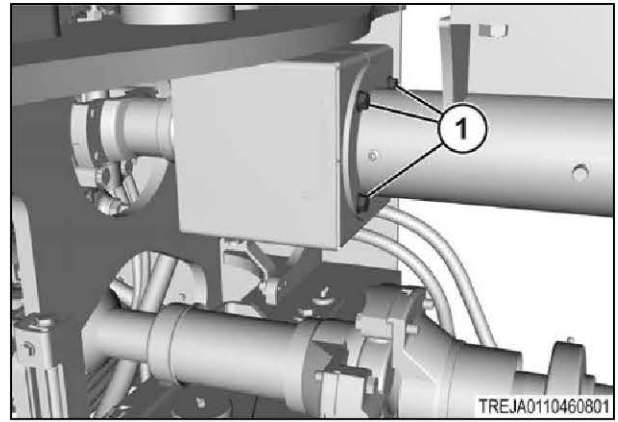

Fig. 7

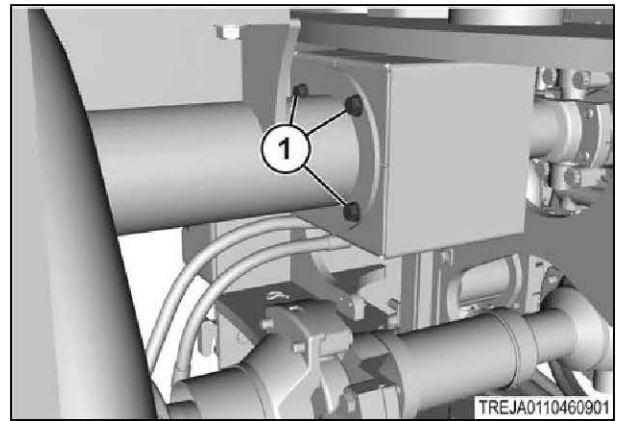

Fig. 8

3. Remove the cover (1) for the front universal joint.

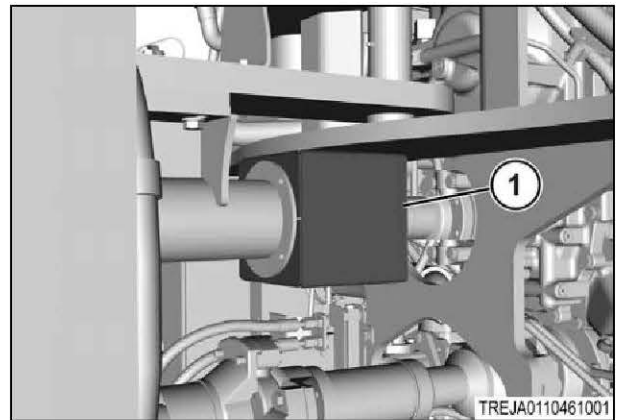

Fig. 9

## 15. Implement drive system

4. Remove the four bolts (1) from the cover of the rear universal joint.

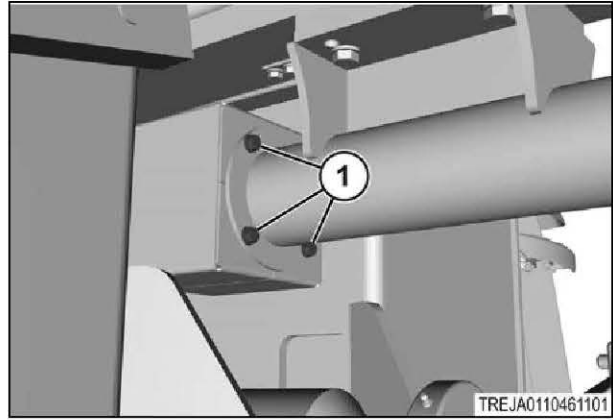

Fig. 10

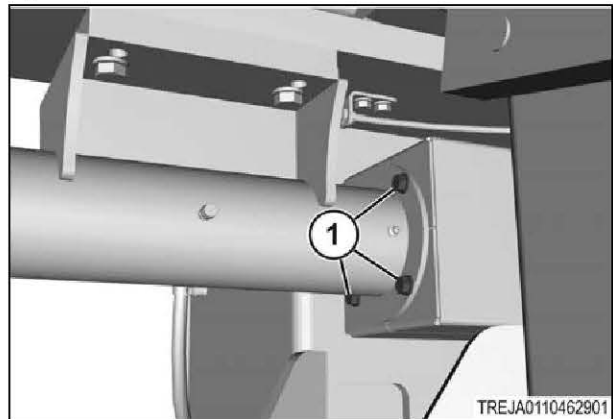

Fig. 11

5. Remove the cover (1) for the rear universal joint.
6. Use correct lifting equipment to support the rear PTO drive shaft.

**IMPORTANT:**

*The weight of the rear PTO drive shaft is approximately 32 kg (70 lb).*

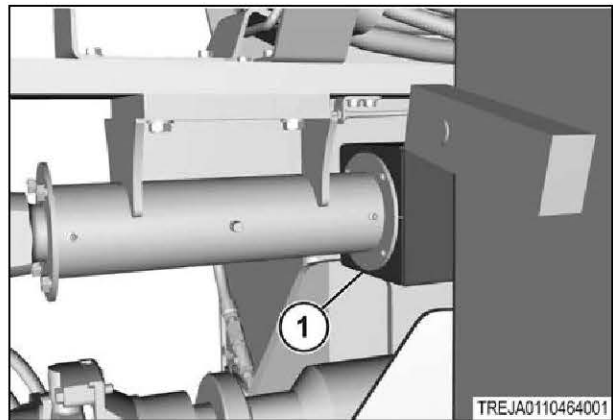

Fig. 12

7. Remove the four bolts (1) from the rear power take-off (PTO) drive shaft universal joint.

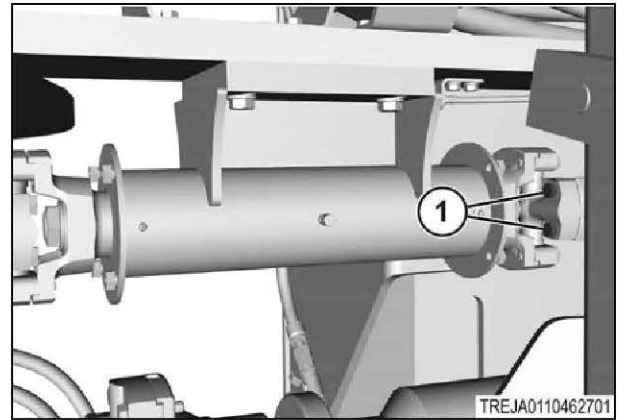

Fig. 13

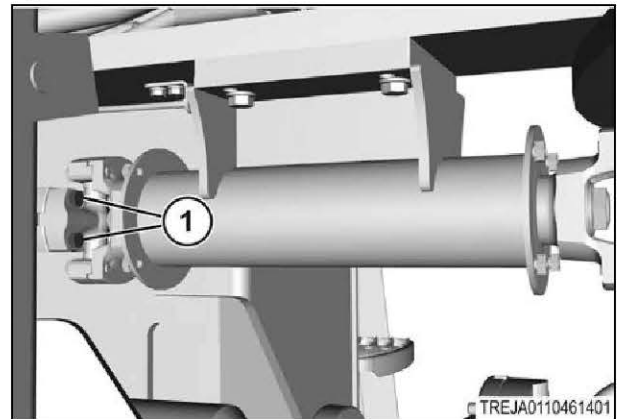

Fig. 14

8. Remove the four bolts (1) from the front power take-off (PTO) drive shaft universal joint.
9. Use correct lifting equipment to support the middle PTO drive shaft.

**IMPORTANT:**

*The weight of the middle PTO drive shaft is approximately 40 kg (88 lb).*

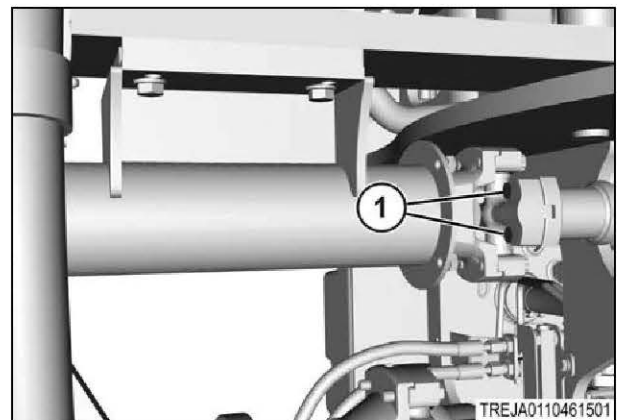

Fig. 15

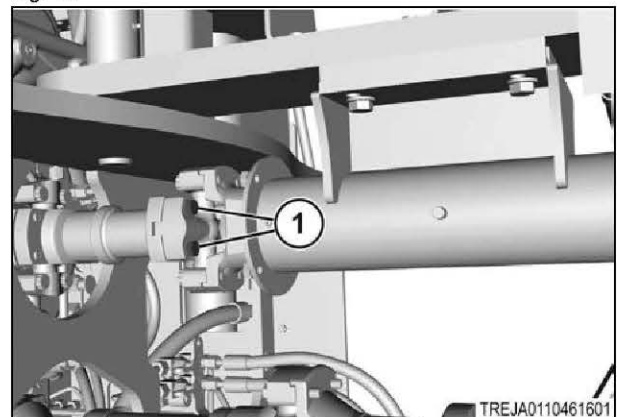

Fig. 16

10. Remove the four bolts (1) that fasten the PTO drive shaft to the frame.

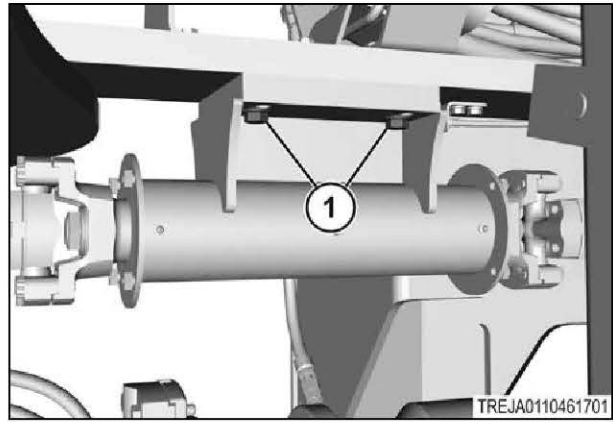

Fig. 17

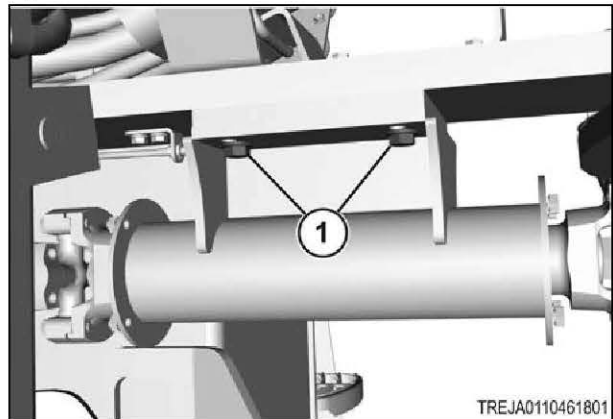

Fig. 18

11. Remove the middle PTO drive shaft (1) and the spacer plates (2).
12. Use correct lifting equipment to support the front PTO drive shaft.

**IMPORTANT:**

*The weight of the front PTO drive shaft is approximately 12 kg (26 lb).*

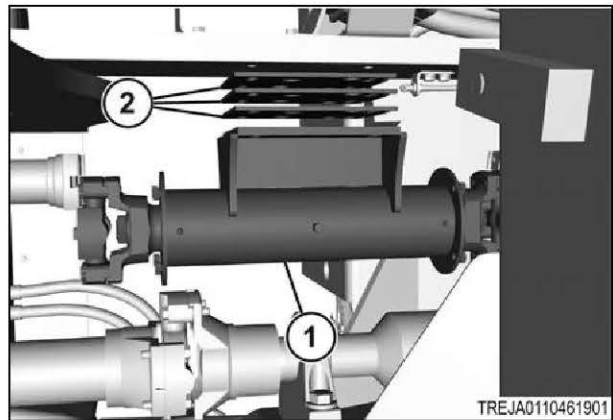

Fig. 19

13. Remove the four bolts (1) that fasten the front PTO drive shaft to the yoke on the PTO clutch assembly.

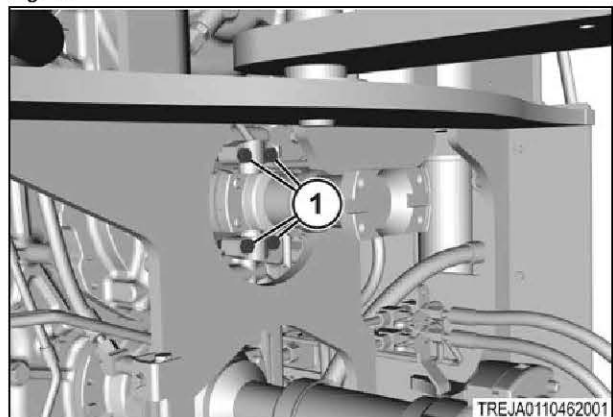

Fig. 20

14. Remove the front PTO drive shaft (1).

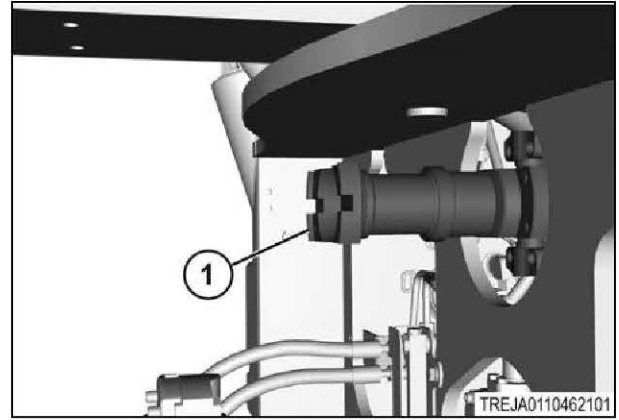

Fig. 21

15. Remove the bolt and washer (1) from the rear PTO drive shaft cover.

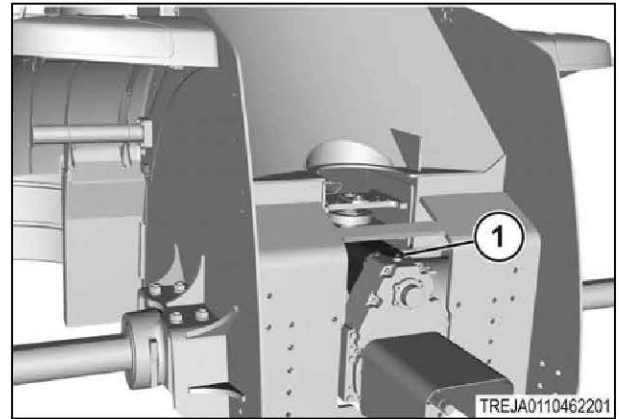

Fig. 22

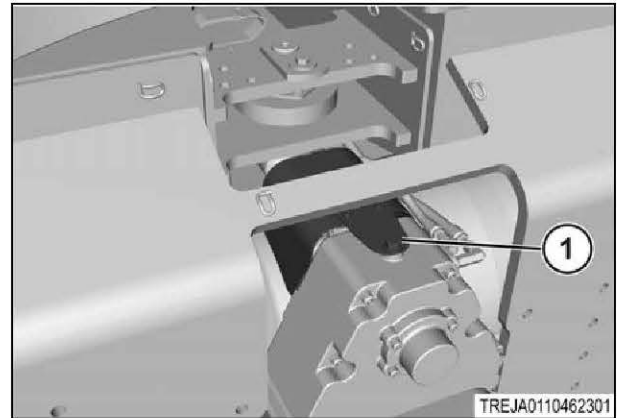

Fig. 23

15. Implement drive system

- 16. Remove the two bolts (1) from the rear PTO drive shaft cover.
- 17. Use correct lifting equipment to support the rear PTO drive shaft.

**IMPORTANT:**

*The weight of the rear PTO drive shaft is approximately 32 kg (70 lb).*

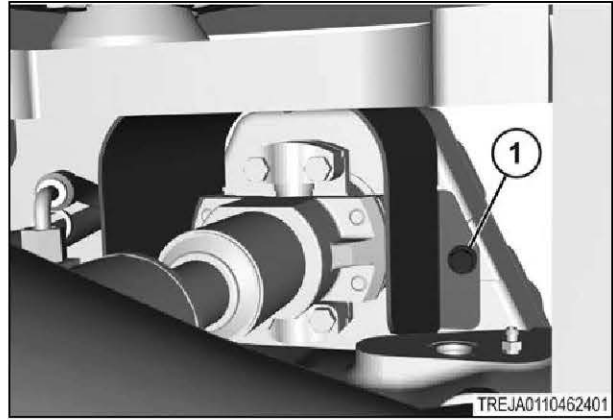

Fig. 24

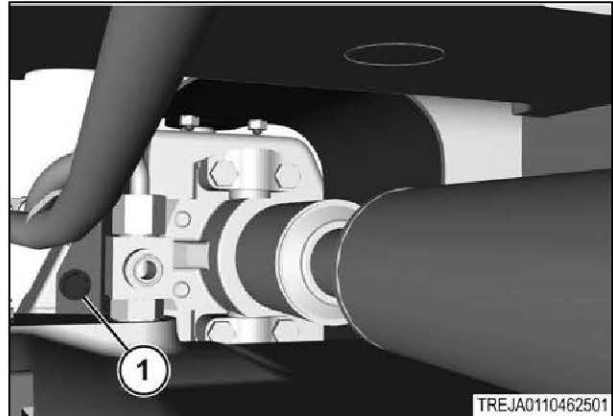

Fig. 25

- 18. Remove the bolts (1) that fasten the rear PTO drive shaft to the rear axle gear box.

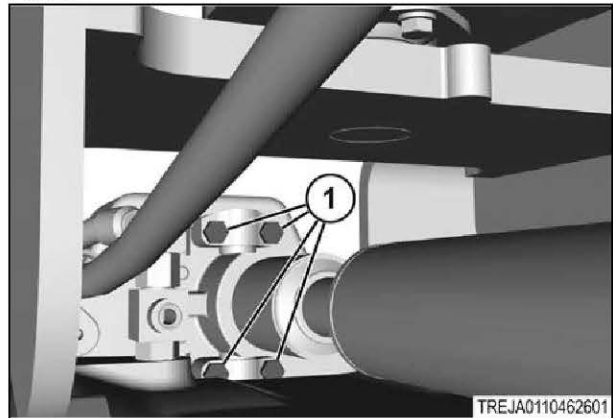

Fig. 26

### 15.2.4 Disassemble the power take-off drive shaft

#### Procedure

1. Remove the the lock nut (2) to remove the yoke (1).

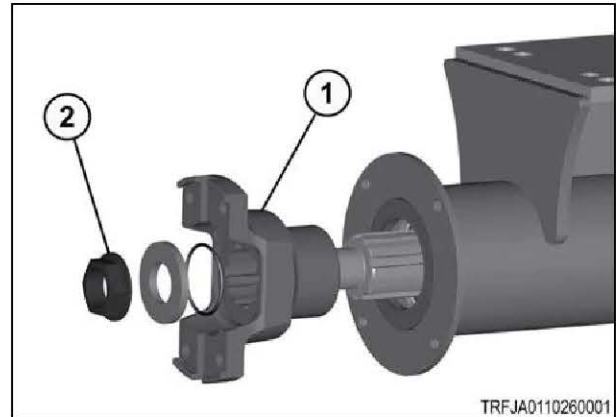

Fig. 27

2. Remove the seal (1).

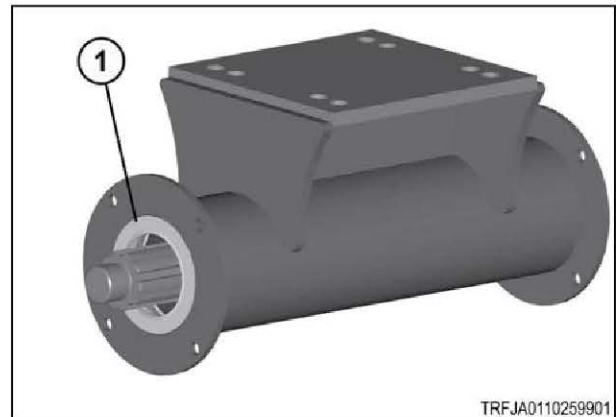

Fig. 28

3. Remove the bearing (1).
4. Repeat for the other side of the shaft.

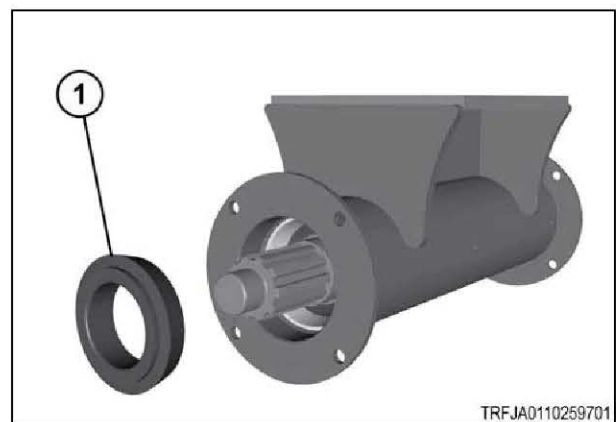

Fig. 29

15. Implement drive system

5. Remove the shaft (1) from the bore of the housing (2).

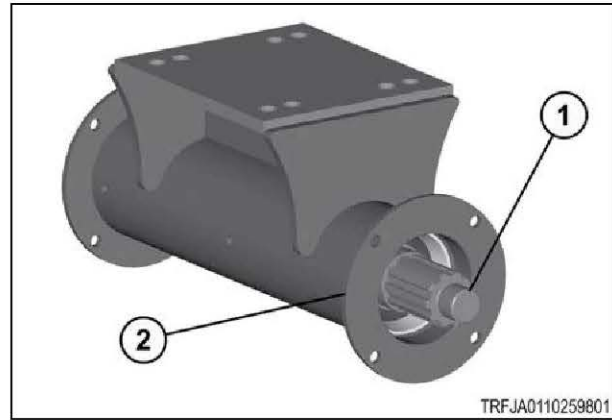

Fig. 30

6. Remove the bearing cup (1).
7. Repeat for the opposite side of the housing.

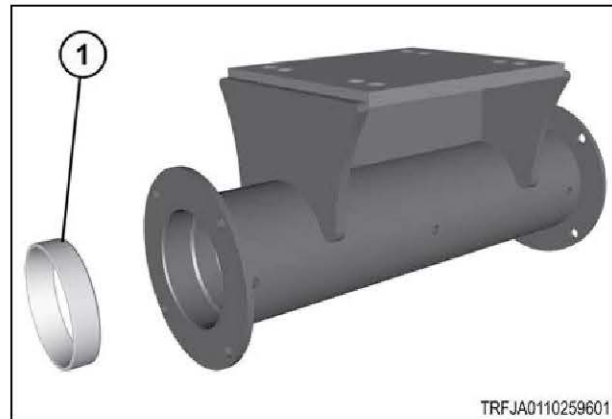

Fig. 31

**15.2.5 Assemble the power take-off drive shaft**

**Procedure**

1. Install the bearing cup (1) with the drive tool.
2. Repeat for the opposite side of the housing.
3. Put the housing horizontally on a work bench.
4. Tightly attach the housing to the work bench.

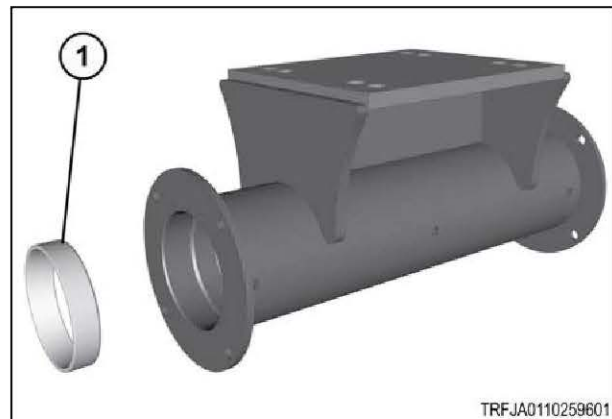

Fig. 32

5. Install the shaft (1) into the bore of the housing (2). Do not damage the shaft.

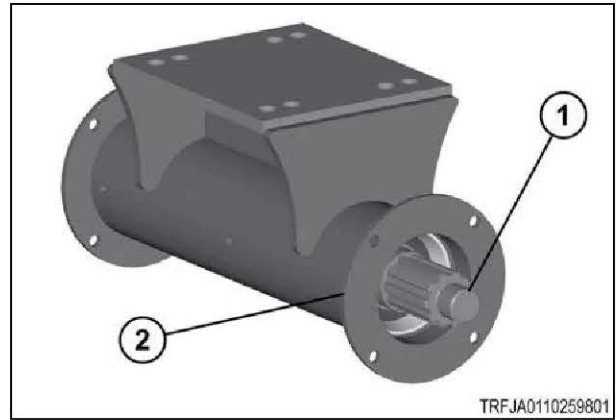

Fig. 33

6. Increase the temperature of the bearing (1) to 115 °C (240 °F)
7. Install the bearing on the shaft until the race is 2 mm to 3 mm (0.08 inch to 0.12 inches) from the end of the bearing journal.
8. Wait 5 to 10 minutes to let the bearing become cool.
9. Fill the bearing rollers with NLGI #2 grease.
10. Put the shaft in position.

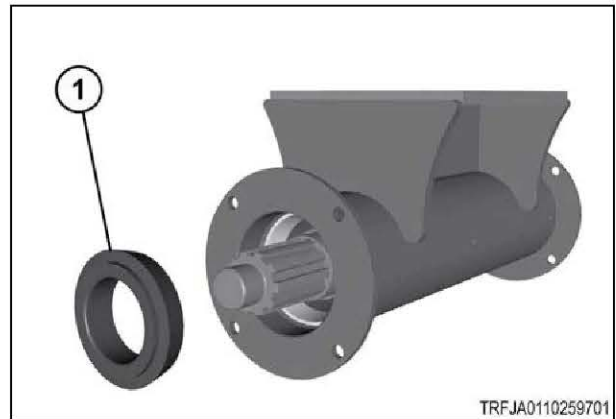

Fig. 34

11. Install the seal (1) with the drive tool.

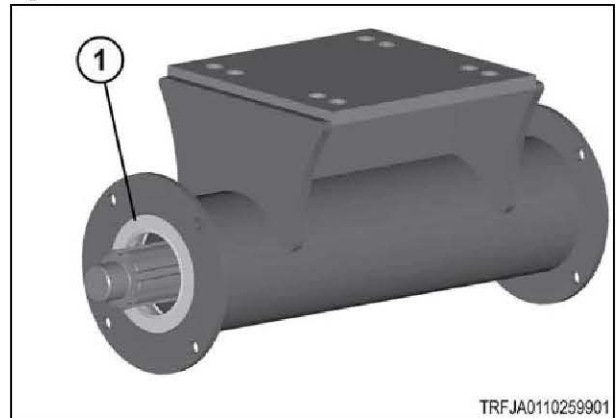

Fig. 35

12. Carefully install the yoke (1) with the lock nut (2).
13. Tighten the lock nut until the yoke is against the bearing.

**IMPORTANT:** Do not press the bearing further onto the shaft at this time.

14. Repeat steps 6 through 13 for the opposite bearing installation. Make sure the two yokes align.
15. Evenly tighten each lock nut until a small amount of free play remains.

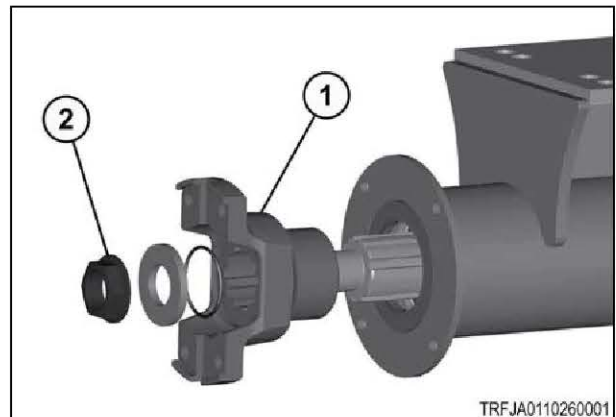

Fig. 36

15. Implement drive system

**NOTE:** 1/6 of a rotation on the lock nut is equivalent to 0.235 mm (0.0093 inches).

16. Measure the free play with a dial indicator.
17. Push the shaft towards the first bearing.
18. Rotate the shaft for five revolutions.
19. Push the shaft towards the second bearing.
20. Rotate the shaft for five revolutions.
21. Measure the free play with a dial indicator.
22. Evenly tighten each lock nut if there is free play in the shaft.
23. Repeat steps 16 through 22 until there is no free play.

**IMPORTANT:** Do not preload the bearings. The shaft must rotate smoothly.

24. Install the lubrication fittings (1).
25. Install the vent (2).
26. Lubricate each bearing (20 pumps per bearing).
27. The rotating shaft assembly must be balanced to less than 1.0 ounce-inch at 3000 RPM.

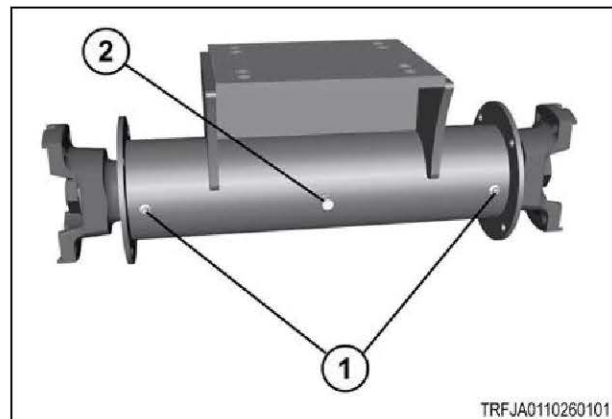

Fig. 37

### 15.2.6 Install the power take-off drive shaft

**Procedure**

1. Park the machine on a solid, level surface. Stop the engine, apply the parking brake, and take the key with you.
2. Use correct lifting equipment to support the rear power take-off (PTO) drive shaft.

**IMPORTANT:**

The weight of the rear PTO drive shaft is approximately 32 kg (70 lb).

3. Install the rear (PTO) drive shaft to the rear axle gear box with four bolts (1).

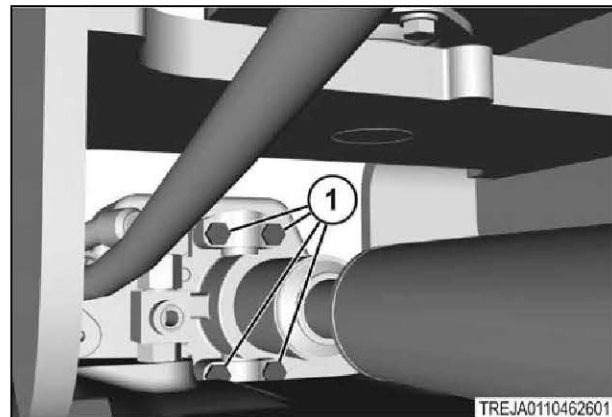

Fig. 38

4. Install the rear PTO drive shaft cover and fasten the rear PTO drive shaft with the bolts (1).

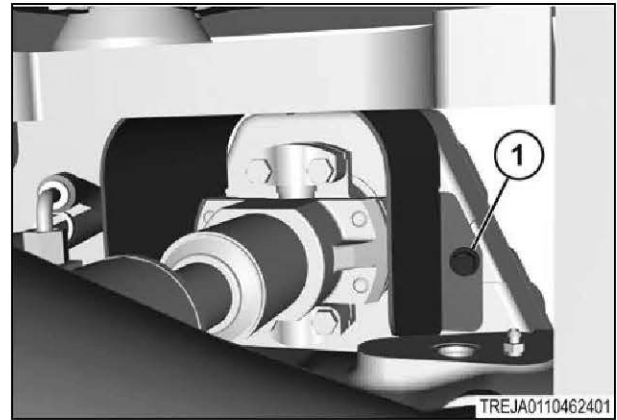

Fig. 39

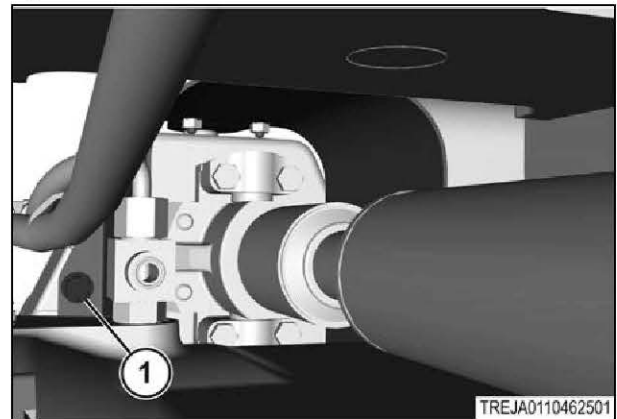

Fig. 40

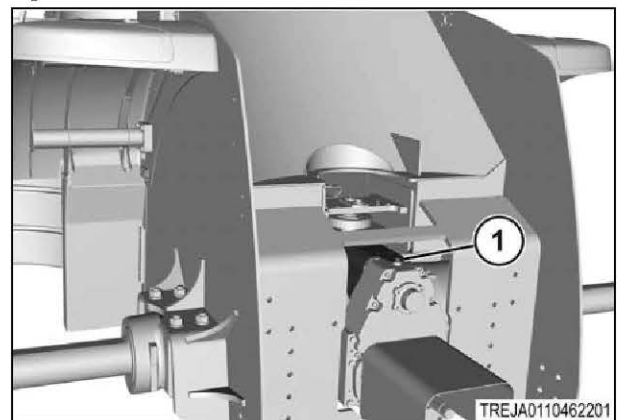

Fig. 41

5. Install the front PTO drive shaft and fasten the front PTO drive shaft with the four bolts (1).

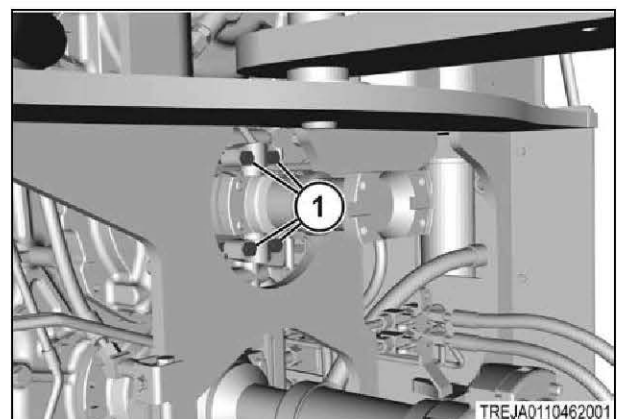

Fig. 42

15. Implement drive system

6. Fasten a universal joint (2) to each end of the middle PTO drive shaft with four bolts (1).

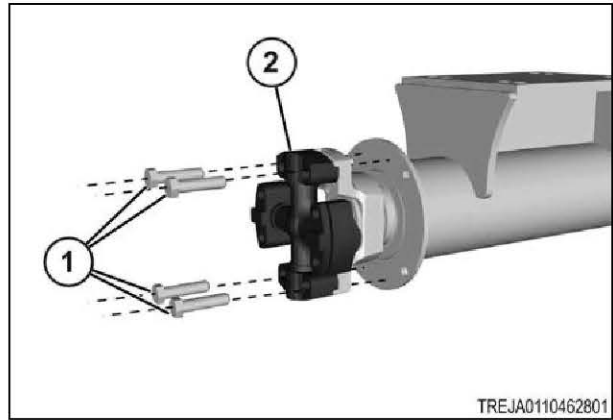

Fig. 43

7. Use a correct lifting device to support the middle PTO drive shaft.
8. Install the spacer plates (2) and the middle PTO drive shaft (1).

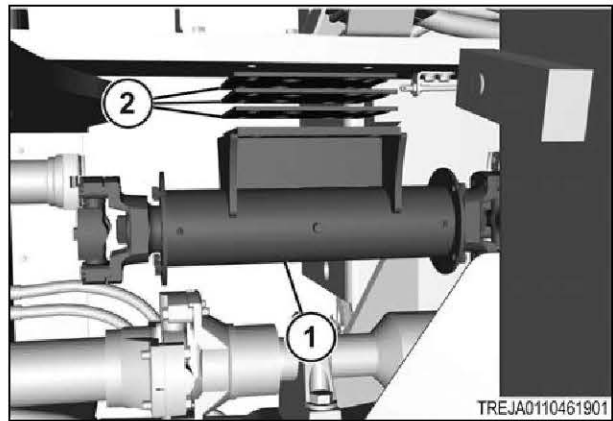

Fig. 44

9. Fasten the spacer plates and the middle PTO drive shaft with bolts.

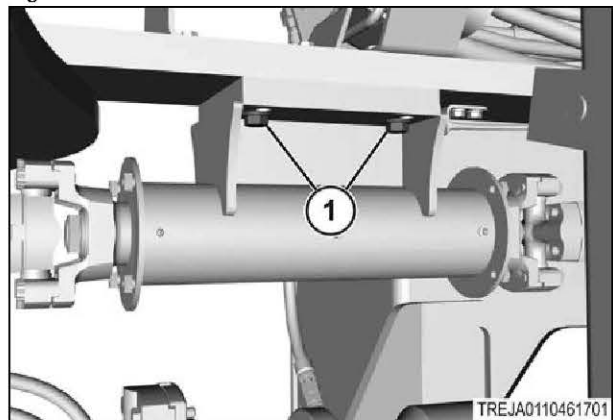

Fig. 45

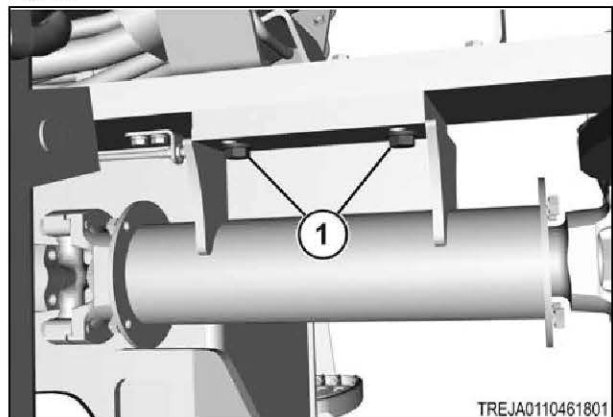

Fig. 46

10. Install four bolts (1) to fasten the middle PTO drive shaft to the front PTO drive shaft.

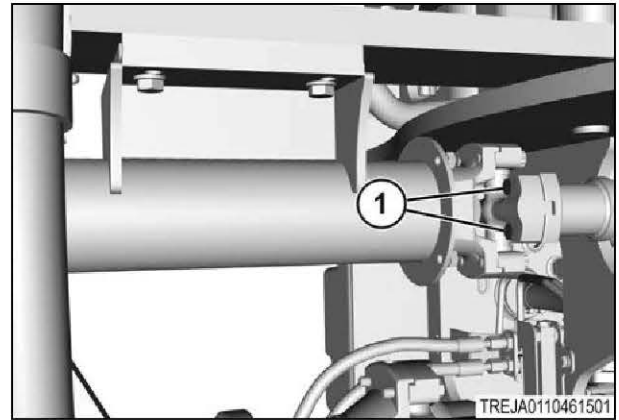

Fig. 47

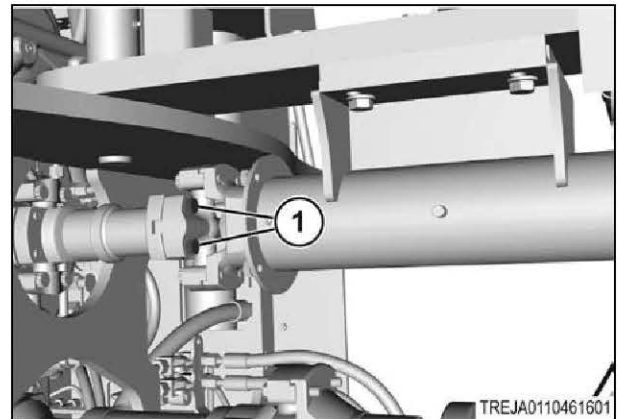

Fig. 48

11. Install four bolts (1) to fasten the middle PTO drive shaft to the rear PTO drive shaft.

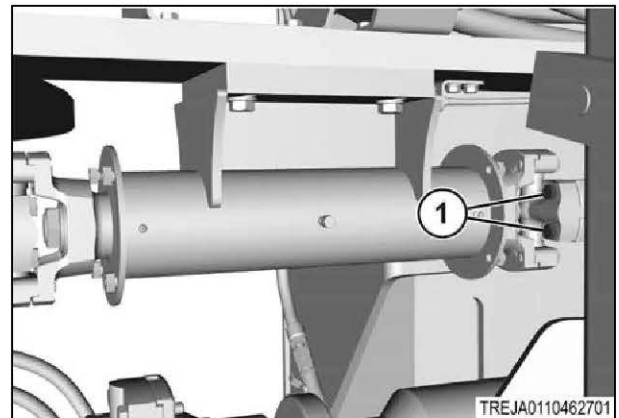

Fig. 49

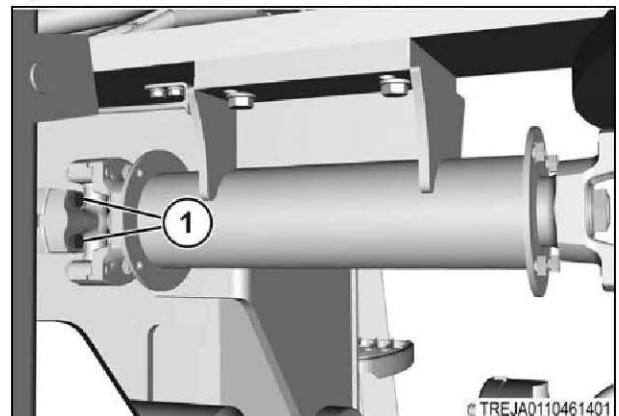

Fig. 50

- 12. Install the cover (1) for the rear universal joint.

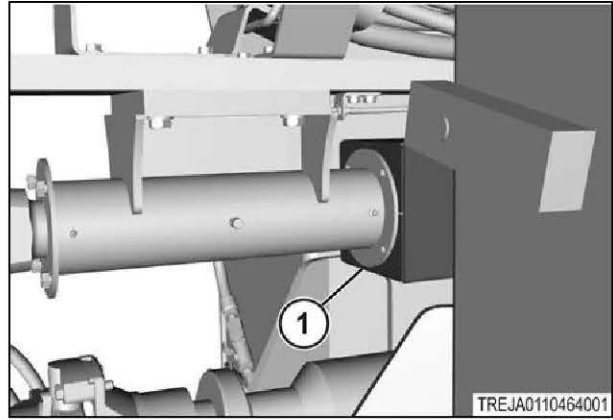

Fig. 51

- 13. Fasten the cover of the rear universal joint with the four bolts (1).

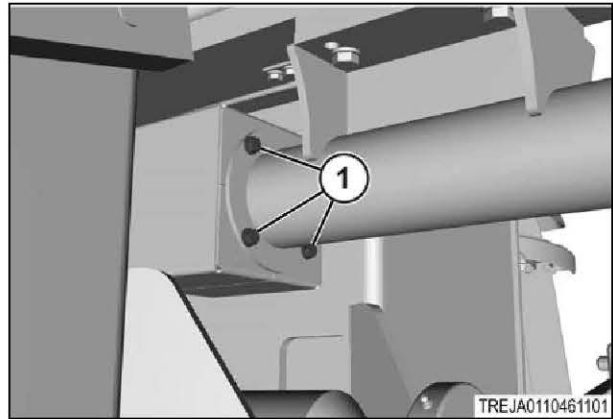

Fig. 52

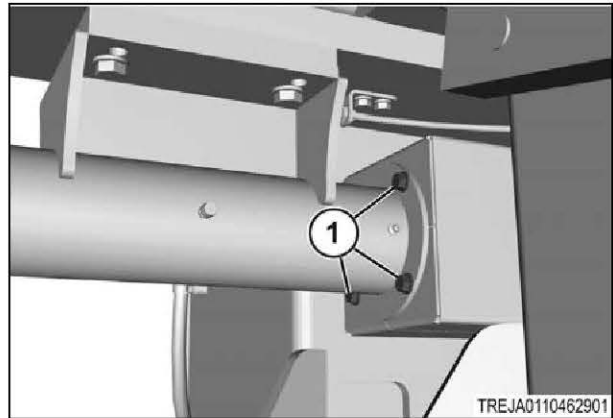

Fig. 53

- 14. Install the cover (1) for the front universal joint.

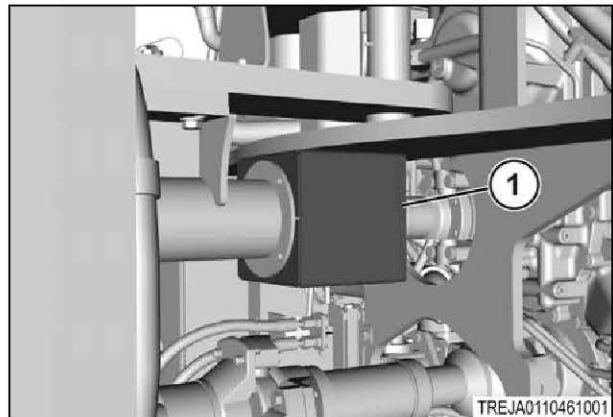

Fig. 54

15. Fasten the cover for the front universal joint with the four bolts (1).

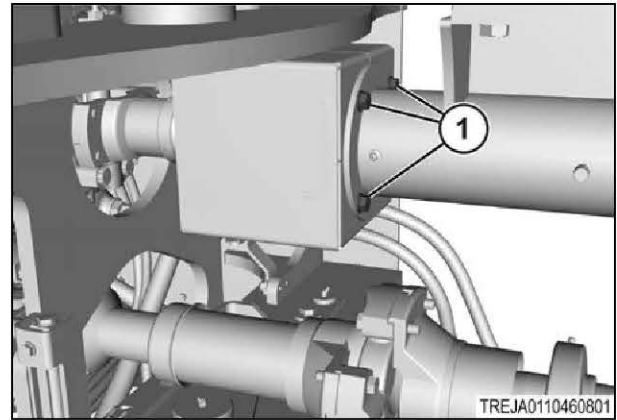

Fig. 55

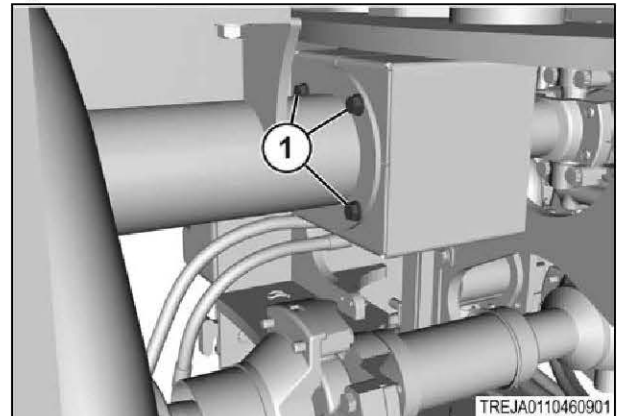

Fig. 56

### 15.2.7 Remove the power take-off clutch assembly

#### Procedure

1. Remove the transmission.
2. Disconnect the tube (1) from the valve block.

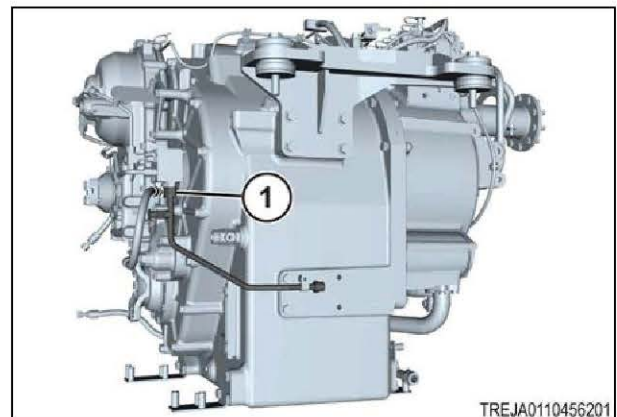

Fig. 57

15. Implement drive system

3. Remove the bolt and P-clip (1) to remove the tube.

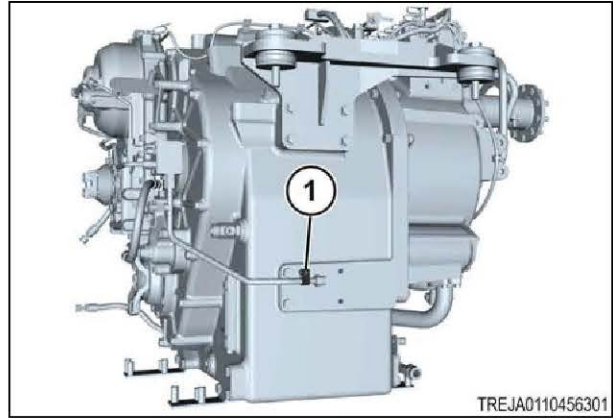

Fig. 58

4. Remove the bolts, washers, and P-clips (1).

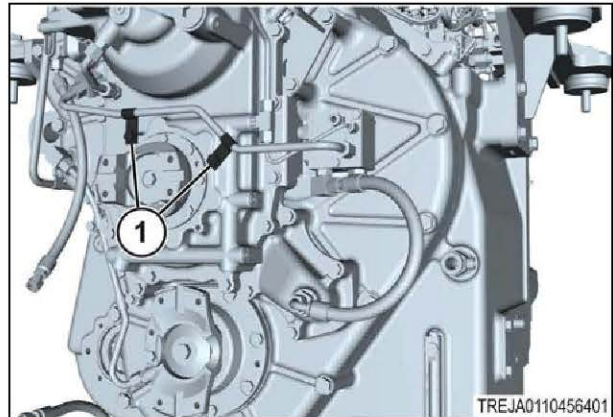

Fig. 59

5. Loosen the tube nuts and remove the tube (1).

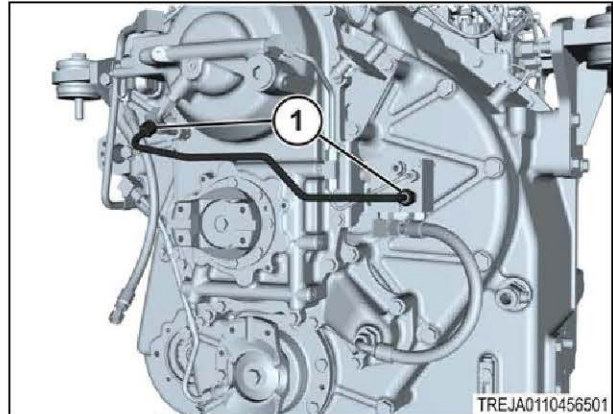

Fig. 60

6. Loosen the tube nuts and remove the tube (1).

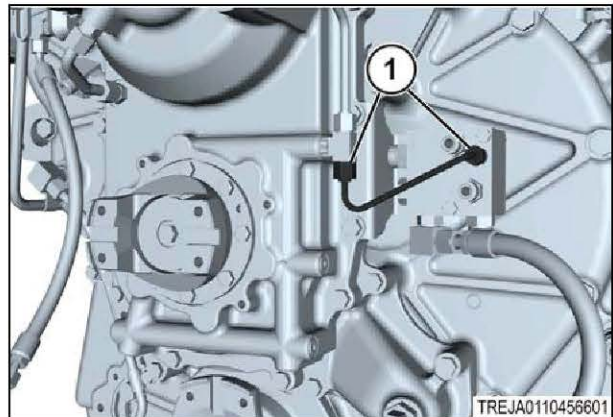

Fig. 61

7. Loosen the hose fittings and remove the hose (1).

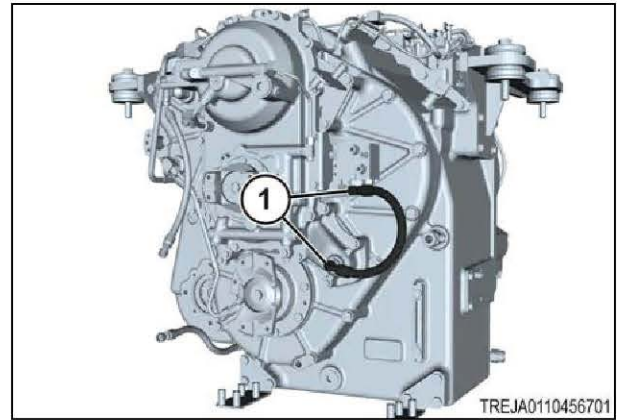

Fig. 62

8. Remove the bolts (1) from the valve block and remove the valve block.

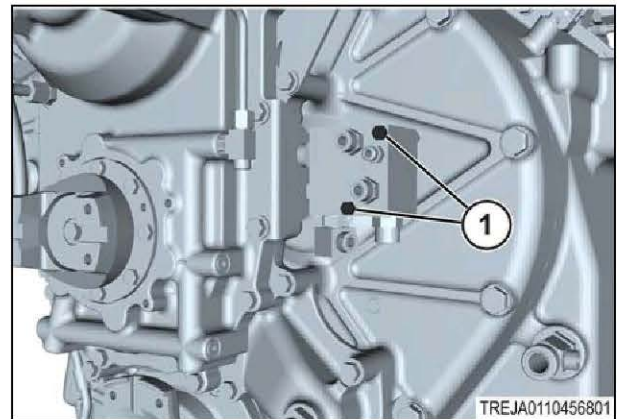

Fig. 63

9. Remove the bolts (1) and the bracket (2) from the power take-off (PTO) clutch assembly.

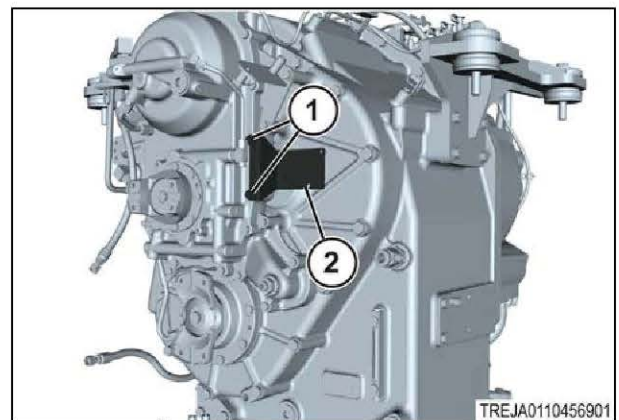

Fig. 64

10. Install the bolts into the PTO clutch assembly.

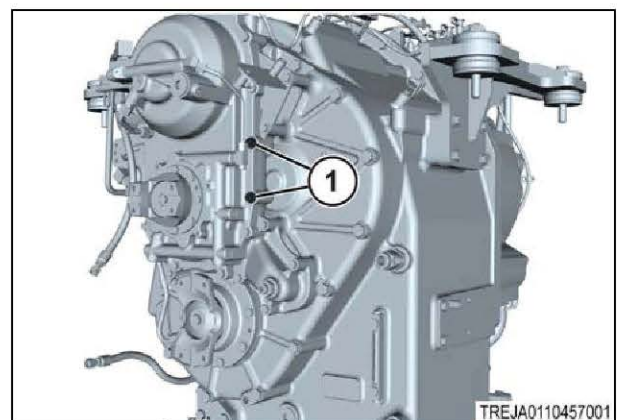
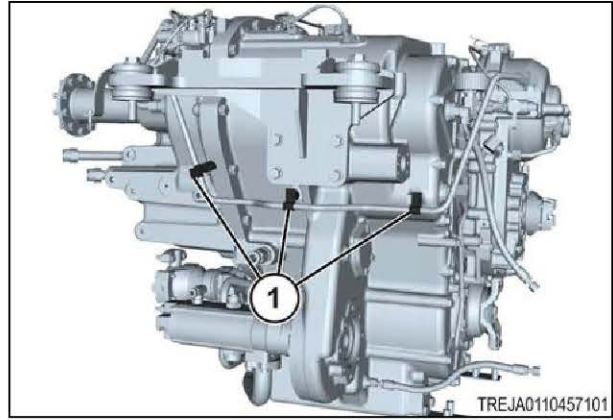

Fig. 65

*15. Implement drive system*

- 11.** Remove the bolts, washers, and P-clips (1) from the transmission.

*Fig. 66*

- 12.** Loosen the tube nuts (1) and remove the tube.

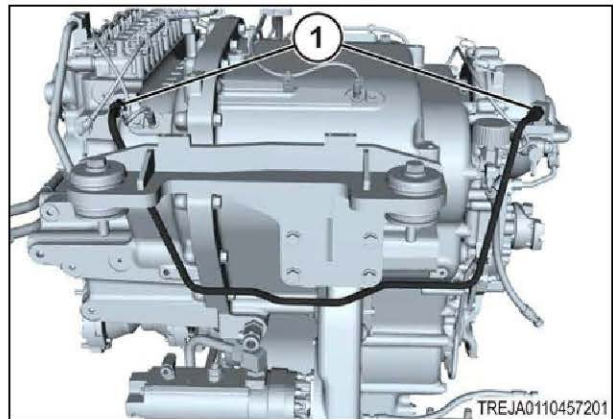
*Fig. 67*

- 13.** Disconnect the wiring harness (1) from the PTO clutch assembly.

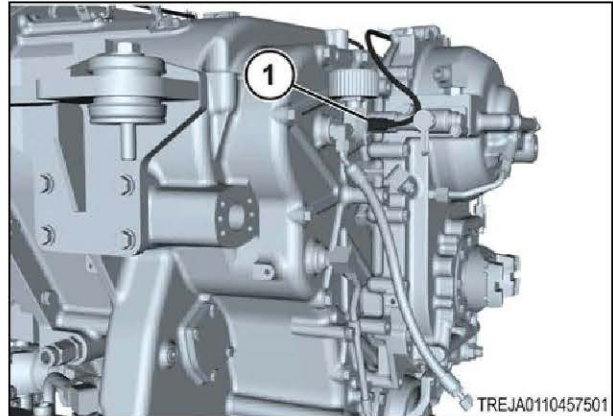
*Fig. 68*

14. Support the PTO clutch assembly.

**IMPORTANT:**

*The weight of the PTO clutch assembly is approximately 45 kg (100 lbs).*

15. Remove the bolts (1) from the PTO clutch assembly.

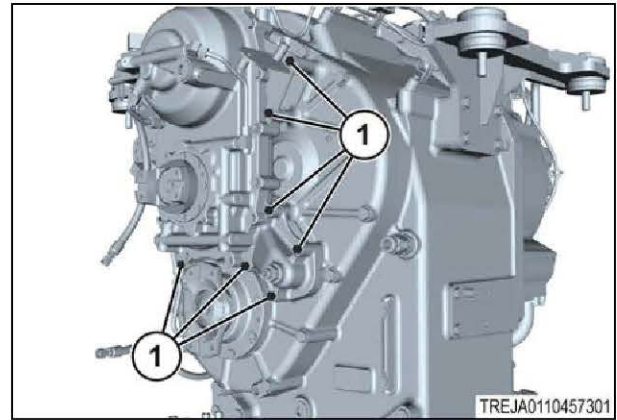

Fig. 69

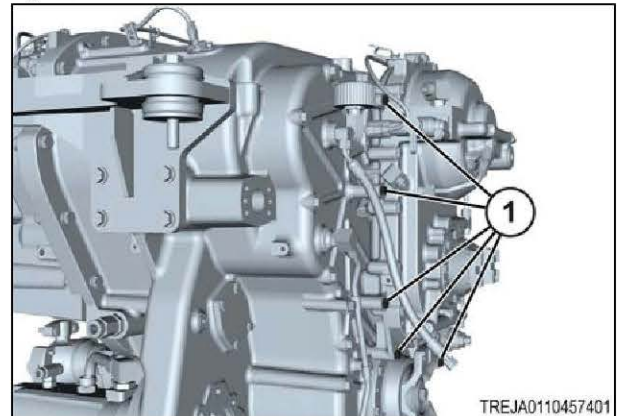

Fig. 70

16. Remove the PTO clutch assembly (1) from the transmission.

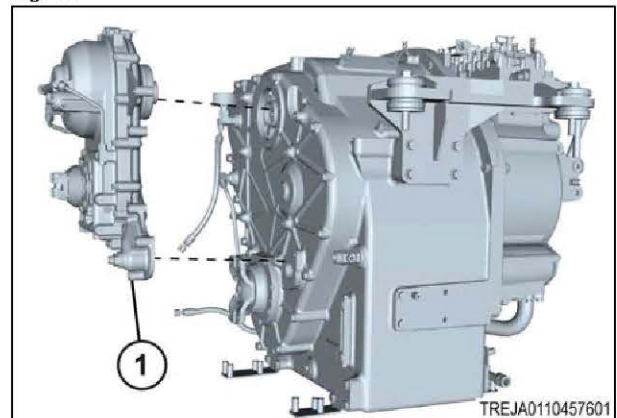

Fig. 71

**Related Links**

[Remove the transmission](#) page 6-9

## 15.2.8 Install the power take-off clutch assembly

### Procedure

1. Remove the bolts and covers (1) from the transmission.

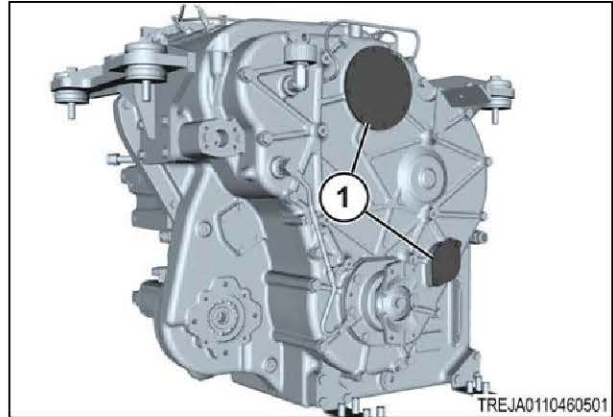

Fig. 72

2. Support the power take-off (PTO) clutch assembly.

**IMPORTANT:**

*The weight of the PTO clutch assembly is approximately 45 kg (100 lbs).*

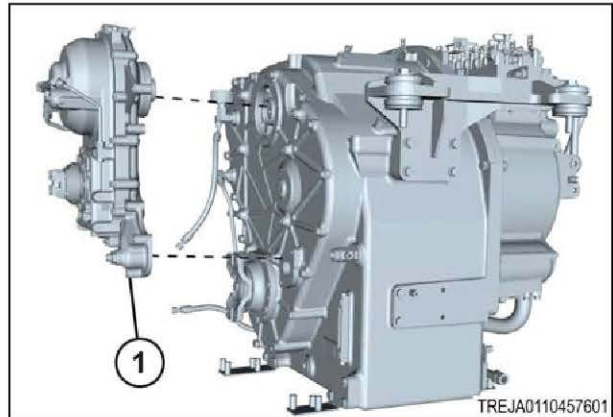

Fig. 73

3. Put the gaskets and Loctite Gasket Maker IU-8846, or other anaerobic adhesive sealant, on the mounting surfaces (1) of the PTO clutch assembly.
4. Put the PTO clutch assembly into position on the transmission.

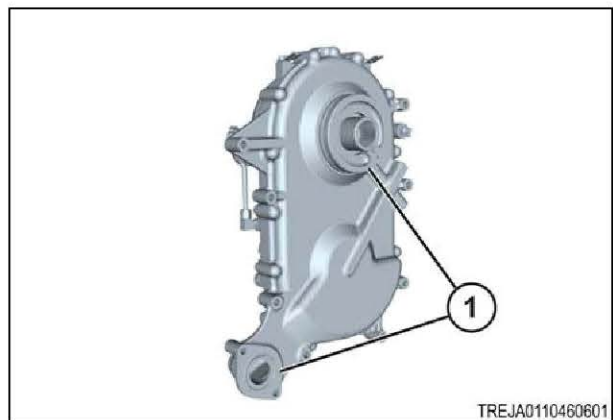

Fig. 74

- 5. Install the bolts and washers (1) to fasten the PTO clutch assembly to the transmission.

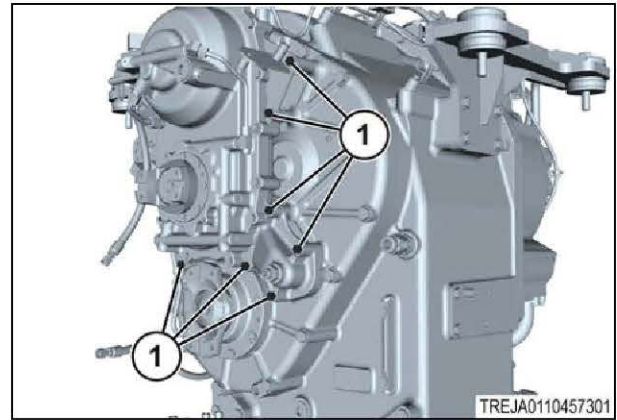

Fig. 75

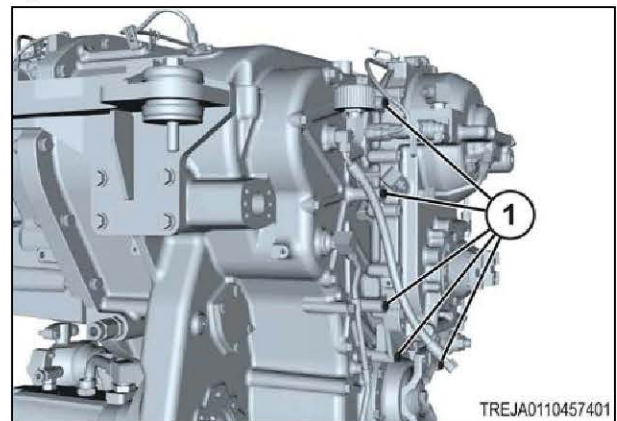

Fig. 76

- 6. Connect the wiring harness (1).

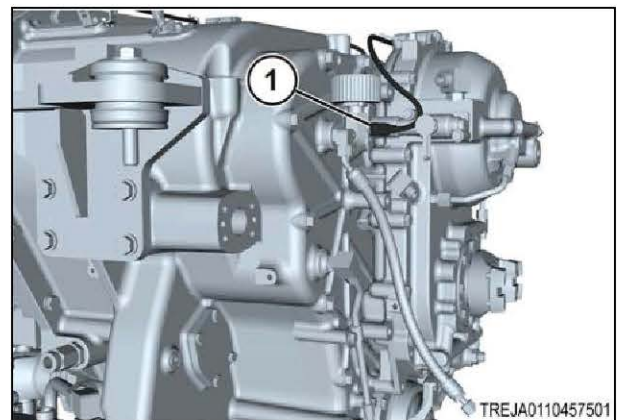

Fig. 77

- 7. Install the tube (1).

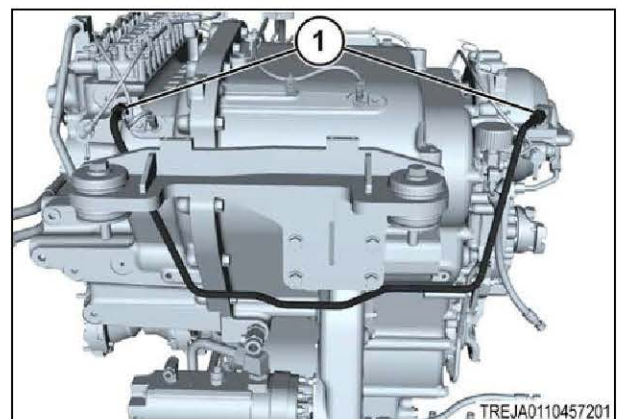

Fig. 78

8. Install the P-clips (1) with bolts and washers.

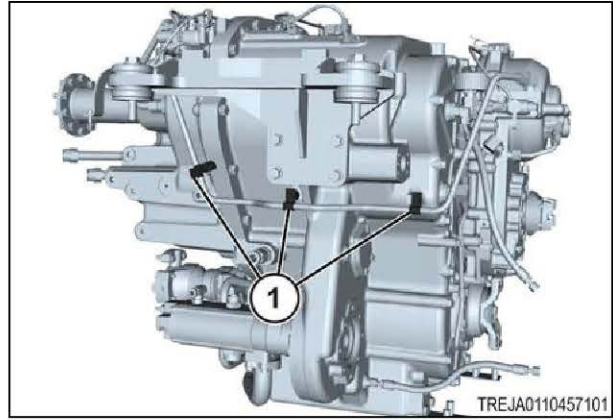

Fig. 79

9. Remove the bolts and washers (1) and keep them.

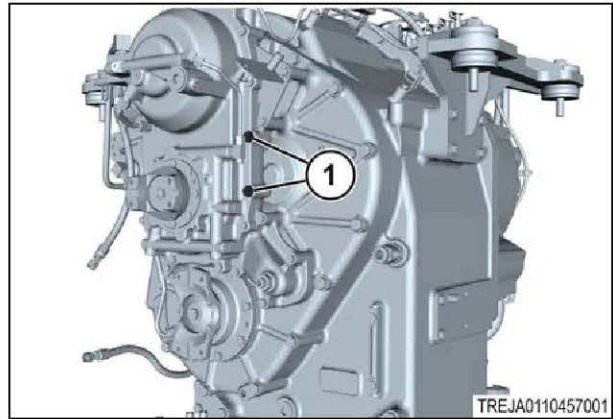

Fig. 80

10. Install the bracket (2) with the bolts and washers (1).

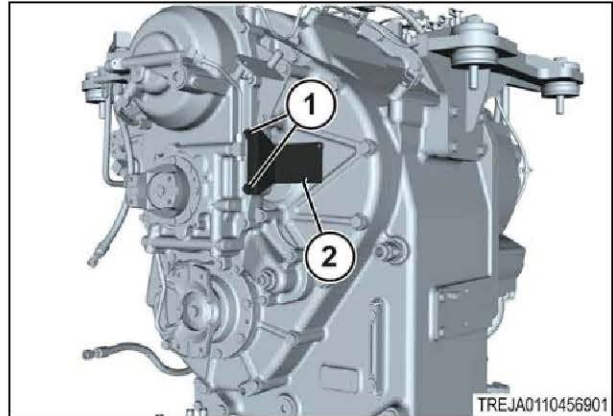

Fig. 81

11. Install the valve block. Fasten the valve block to the transmission with bolts (1).

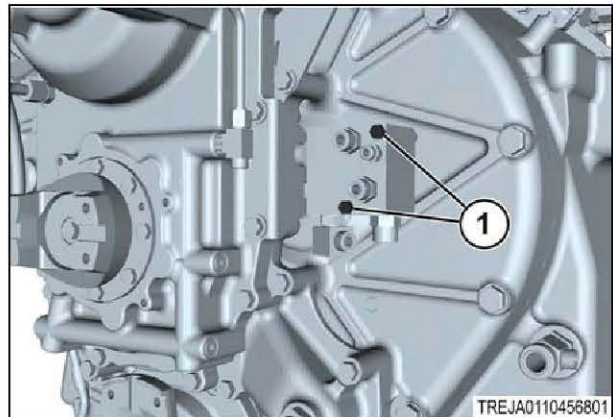

Fig. 82

12. Install the hose (1).

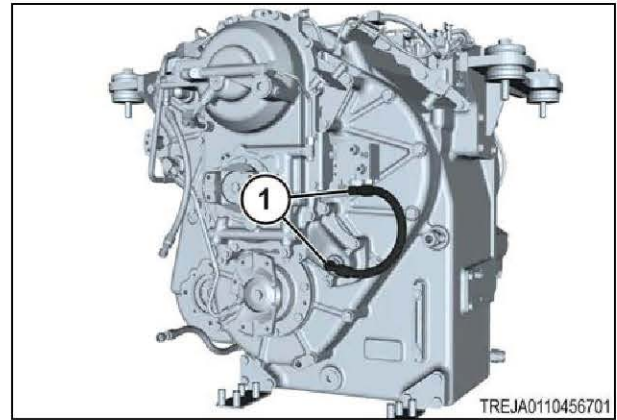

Fig. 83

13. Install the tube (1).

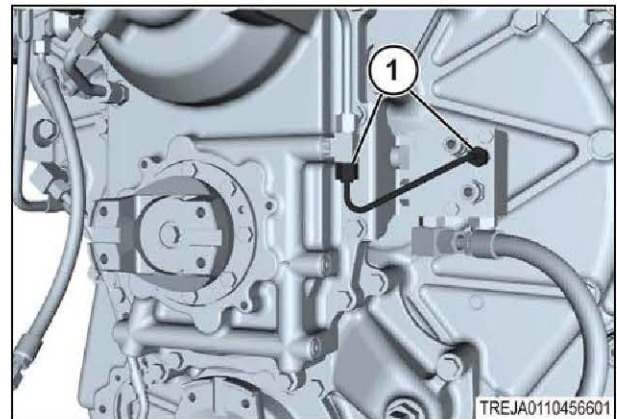

Fig. 84

14. Install the tube (1).

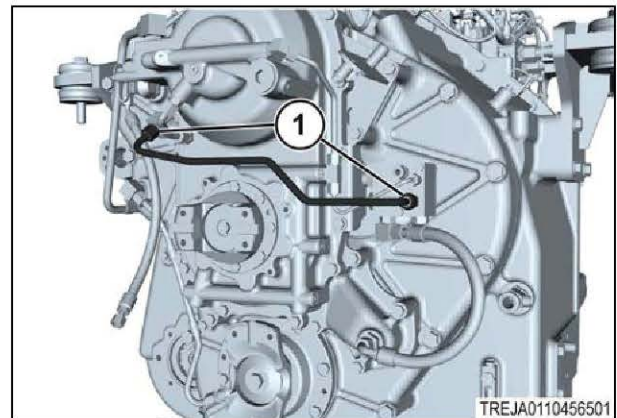

Fig. 85

15. Install the P-clips (1) with bolts and washers.

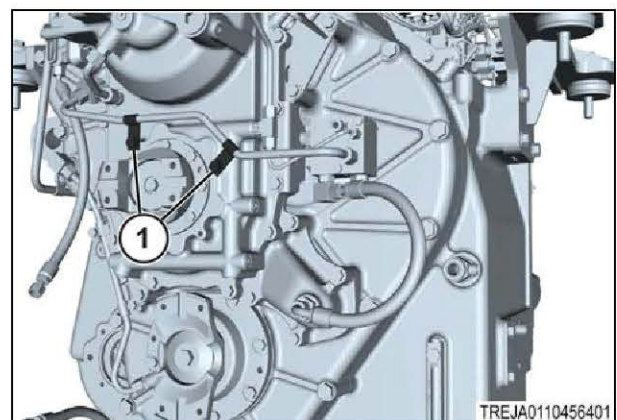

Fig. 86

16. Install the tube (1).

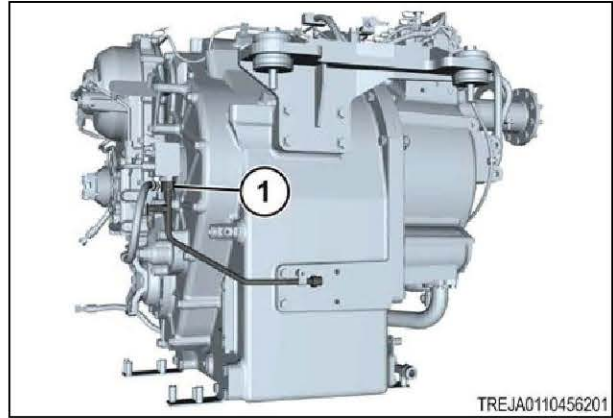

Fig. 87

17. Install the P-clip (1) with a bolt and washer.

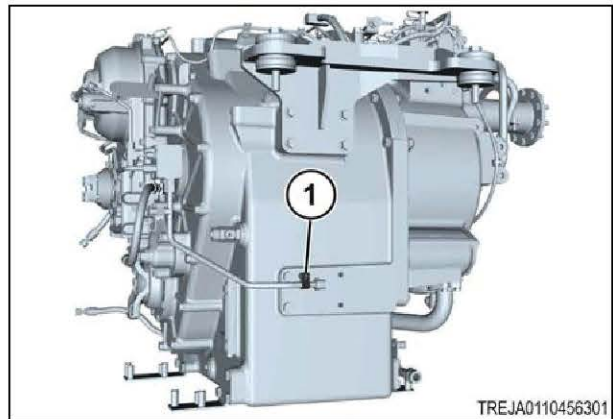

Fig. 88

### 15.2.9 Remove the power take-off gearbox



**WARNING: Hot components can burn.**

**Severe personal injury can result.**

**Let the engine and components cool before doing maintenance.**

#### Procedure

1. Remove the bolts (1,2) and washers from the cover for the rear power take-off (PTO) drive shaft.

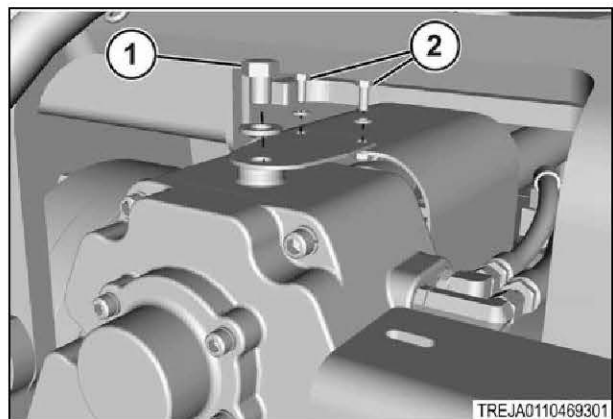

Fig. 89

2. Remove the bolts (1) and washers from the cover for the rear power take-off (PTO) drive shaft.
3. Remove the cover for the rear power take-off (PTO) drive shaft.

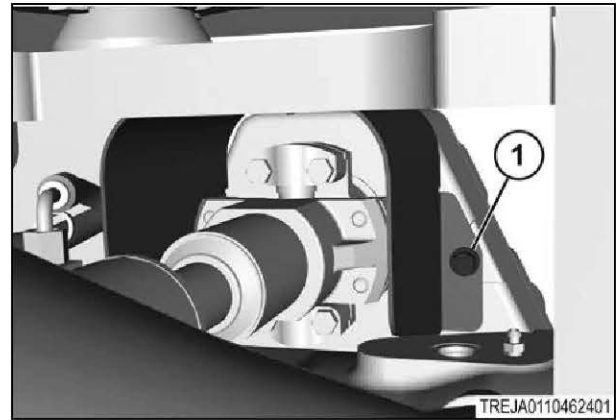

Fig. 90

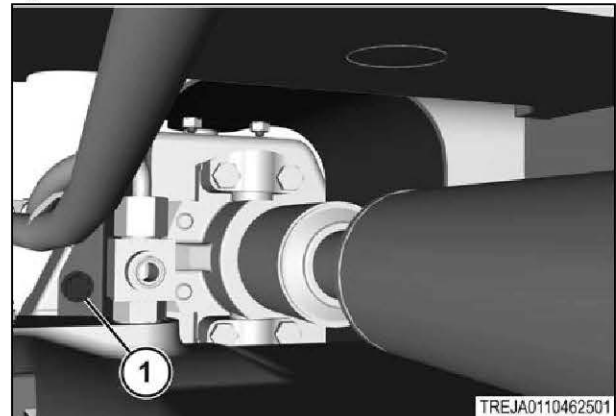

Fig. 91

4. Remove the bolts (1) that fasten the rear PTO drive shaft to the PTO gearbox.

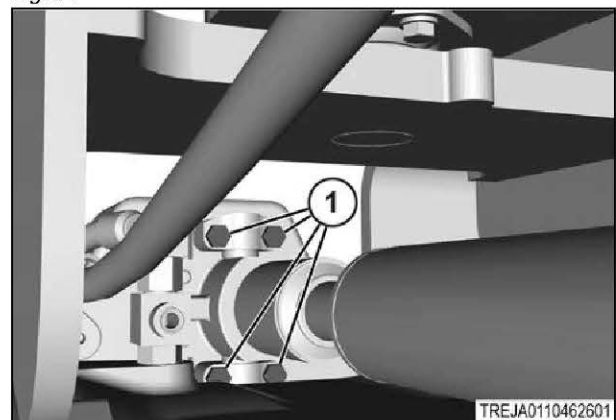

Fig. 92

5. Disconnect the hydraulic hoses (1) from the PTO gearbox.
6. Remove the hydraulic fittings (2) from the PTO gearbox.

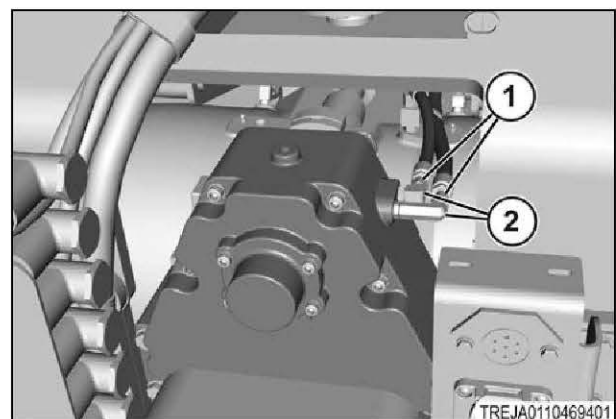

Fig. 93

15. Implement drive system

7. Remove the bolts (1) and washers from the PTO cover.
8. Remove the PTO cover.

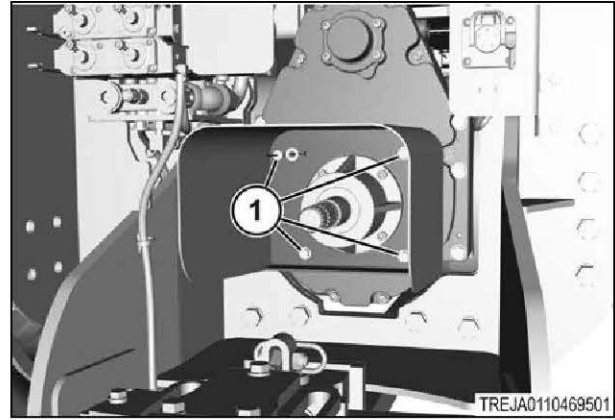

Fig. 94

9. Put a lifting eye bolt in the threaded hole (1) on top of the PTO gearbox.
10. Install a correct lifting device to the lifting eye bolt to support the PTO gearbox.

**IMPORTANT:** The weight of the PTO gearbox is approximately 23 kg (51 lbs).

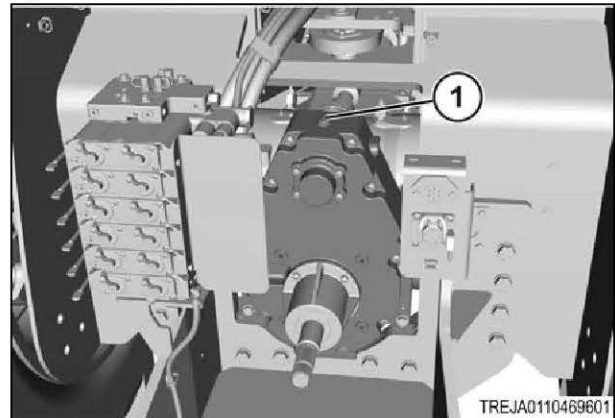

Fig. 95

11. Remove the six bolts and washers (1) from the PTO gearbox and remove the PTO gearbox.

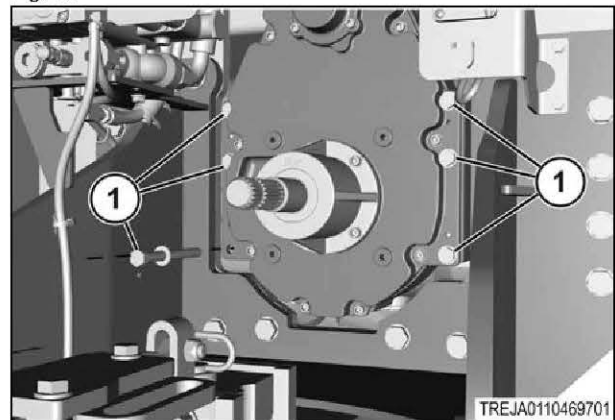

Fig. 96

**15.2.10 Install the power take-off gearbox**



**WARNING:** Hot components can burn.

Severe personal injury can result.

Let the engine and components cool before doing maintenance.

**Procedure**

1. Put a lifting eye bolt in the threaded hole (1) on top of the PTO gearbox.
2. Install a correct lifting device to the lifting eye bolt to support the PTO gearbox.

**IMPORTANT:** The weight of the PTO gearbox is approximately 23 kg (51 lbs).

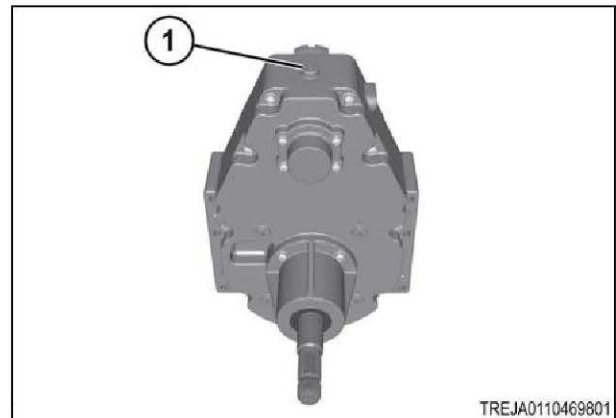

Fig. 97

3. Remove the protective plugs (1) from the rear axle.
4. Remove the threaded plug (2) from the rear axle.
5. Clean the mounting surfaces for the PTO gearbox on the rear axle.

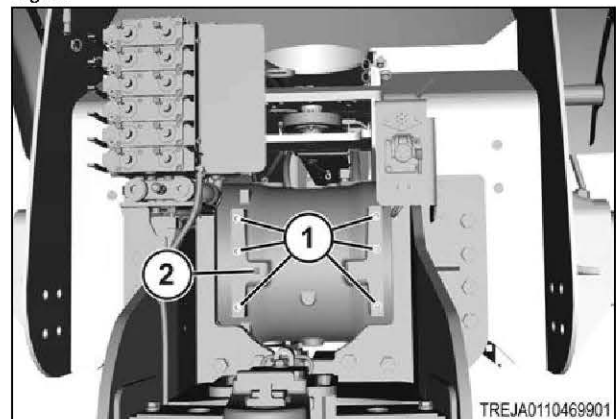

Fig. 98

6. Install the O-ring to the opening (1) on the rear gear box.

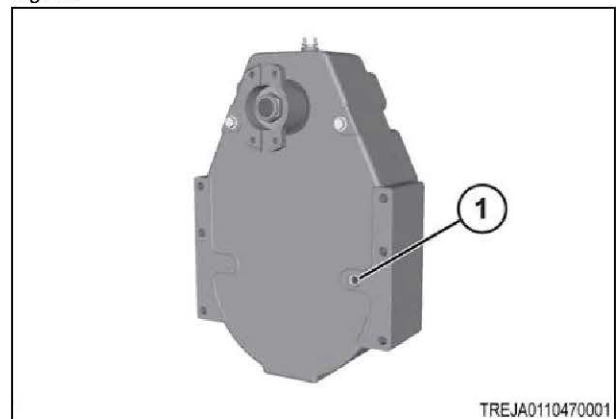

Fig. 99

7. Move the PTO gearbox into position on the rear axle.
8. Fasten the PTO gearbox to the rear axle with the six bolts (1) and washers.

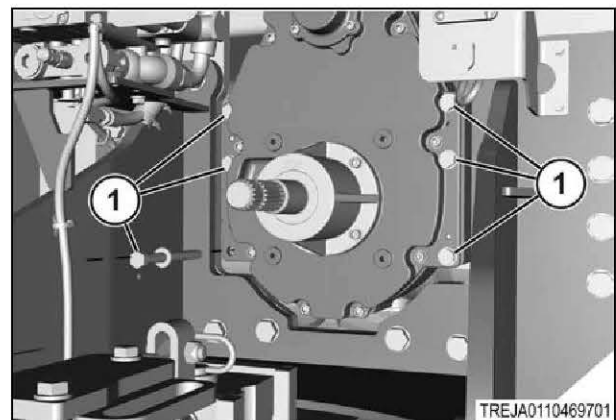

Fig. 100

15. Implement drive system

- 9. Install the hydraulic fittings (2).
- 10. Connect the hydraulic lines (1).

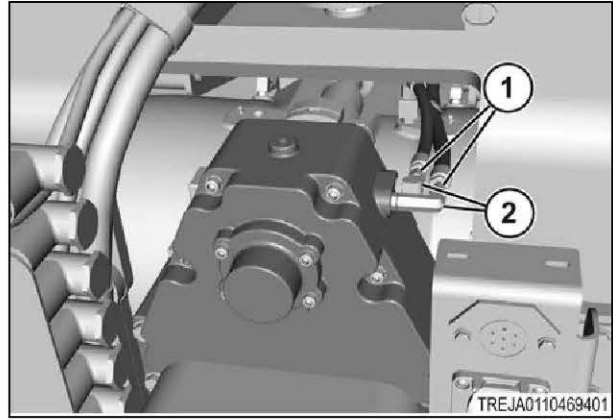

Fig. 101

- 11. Install the PTO cover with four bolts (1) and washers.

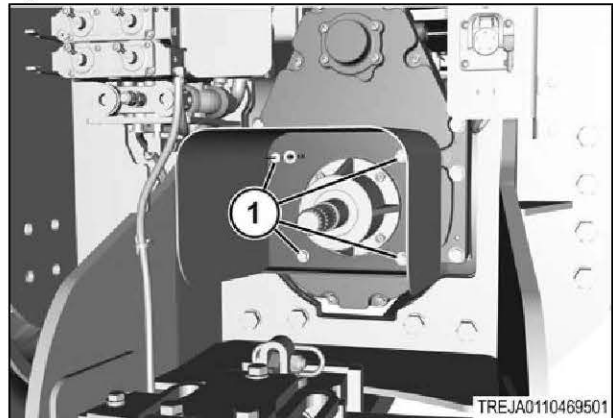

Fig. 102

- 12. Fasten the rear PTO drive shaft to the PTO gearbox with four bolts (1).

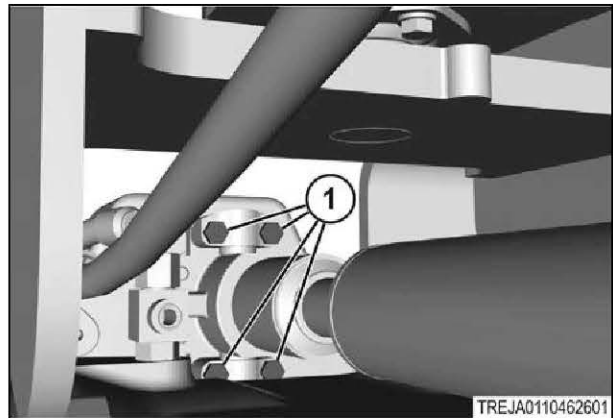

Fig. 103

- 13. Install the rear PTO drive shaft cover.

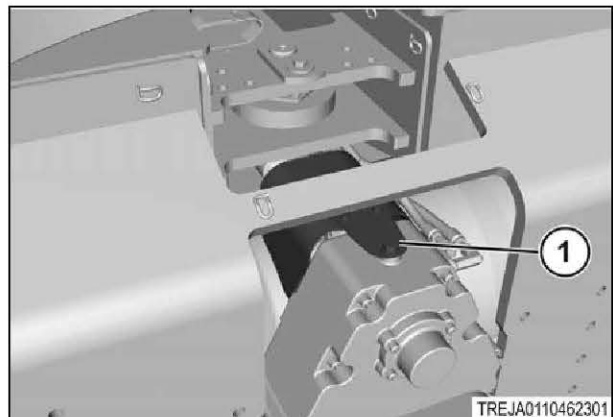

Fig. 104

- 14. Fasten the rear PTO drive shaft cover with two bolts (1).

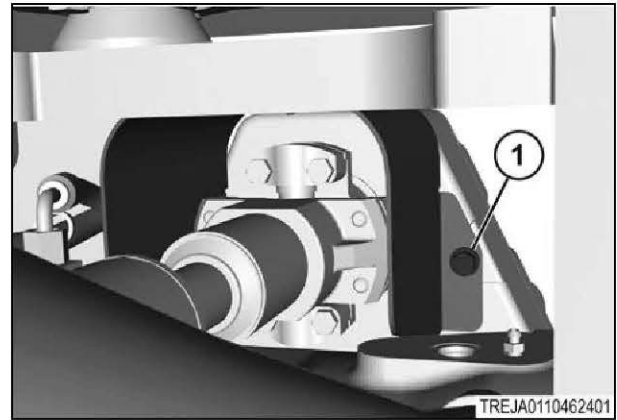

Fig. 105

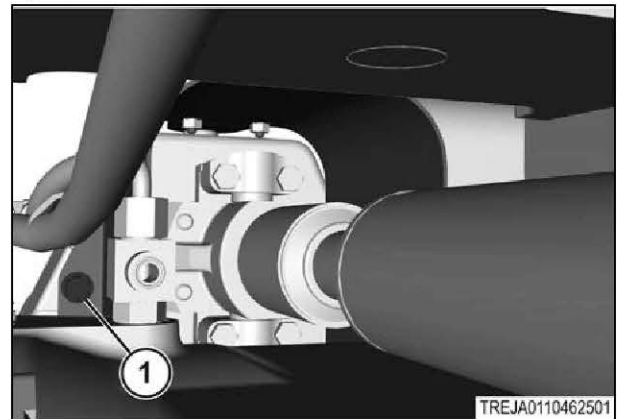

Fig. 106

- 15. Fasten the rear PTO drive shaft cover with bolts (1,2) and washers.

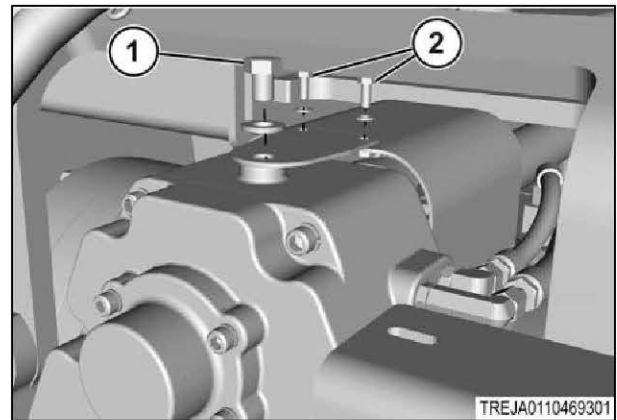

Fig. 107

## 15.3 Power take-off system testing and adjusting

### 15.3.1 Power take-off pressure test introduction

The test procedure checks if the pressure of the oil from the modulating valve to the power take-off (PTO) clutch is in specified limits. There is only one test port on the modulating valve. The oil flow to the PTO clutch is modulated and is not adjustable.

### 15.3.2 Do a test of the power take-off clutch pressure



**CAUTION: Machine movement hazard. Hydraulic pressure release.**

**Personal injury or machine damage can occur.**

**Stand clear of the machine and components when releasing hydraulic pressure.**

**IMPORTANT:** Make sure fluids are contained when servicing the machine. Put fluid in correct containers before servicing parts that contain fluids.

#### Procedure

1. Lower all the implements to the ground and lower the three point hitch to the ground.
2. Make sure the transmission control lever is in the park position.
3. Warm the oil to a minimum temperature of 60°C (140°F).
4. Move all of the hydraulic control levers through float position in order to relieve hydraulic pressure.
5. Stop the engine and remove the key.
6. Connect the pressure gauge to the test port.
7. Start the engine. Operate the engine at high idle.
8. Engage the power take-off.
9. Check the pressure reading on the pressure gauge.

#### Result

Good pressure is 2050 kPa to 2150 kPa (298 psi to 312 psi).

10. Stop the engine.
11. Remove the pressure gauge from the test port.
12. If the pressure is not good, test the charge pressure.

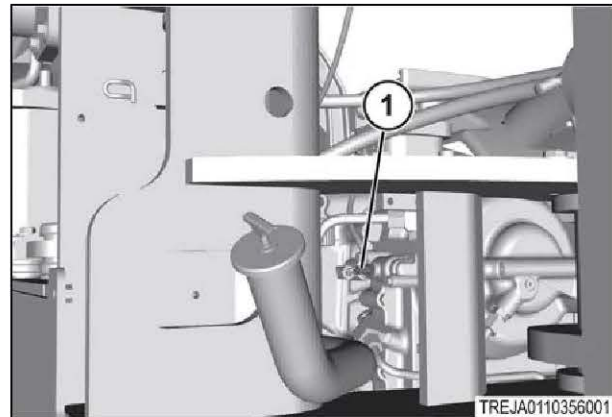

Fig. 108

#### Related Links

[Do a test of the pressure of the power take-off clutch lubricating oil](#) page 15-36

### 15.3.3 Do a test of the pressure of the power take-off clutch lubricating oil



**CAUTION: Machine movement hazard. Hydraulic pressure release.**

**Personal injury or machine damage can occur.**

**Stand clear of the machine and components when releasing hydraulic pressure.**

**Procedure**

1. Park the machine on a smooth and flat surface.
2. Lower all the implements to the ground and lower the 3-point linkage to the ground.
3. Make sure the transmission control lever is in the park position.
4. Warm the oil to a minimum temperature of 60 °C (140 °F).
5. Move all hydraulic control levers through float position in order to release hydraulic pressure.
6. Stop the engine and remove the key.
7. Connect the pressure gauge to the test port (1).
8. Start the engine. Operate the engine at 2100 rpm.
9. Engage the power take-off (PTO).
10. Do a check of the pressure reading on the pressure gauge.

**NOTE:** Do not operate the 3-point linkage while doing a check of the pressure.

**Result**

Good pressure is 500 kPa to 700 kPa (72 psi to 102 psi).

11. Stop the engine.
12. Remove the pressure gauge.

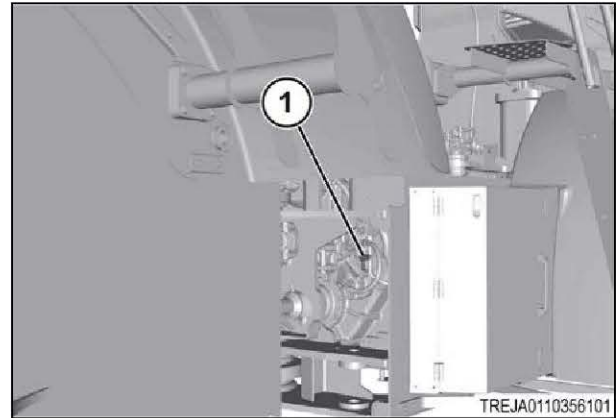

Fig. 109